

Thermal Transfer Printer

TrakMark DS Series

Operating Instruction

Edition 1.1 December 2008



HellermannTyton

Please check our home page for your nearest sales office

Internet: <http://www.hellermanntyton.com/>

Information on the scope of delivery, appearance, performance, dimensions and weight reflects our knowledge at the time of printing. We reserve the right to make modifications.

Table of Contents

1	Introduction.....	3
1.1	Instructions.....	3
1.2	Intended Use.....	3
1.3	Safety Instructions.....	4
1.4	Environment.....	4
2	Installation.....	5
2.1	Device Overview.....	5
2.2	Unpacking and Setting-up the Printer.....	7
2.3	Connecting the Device.....	7
	2.3.1 Connecting to the Power Supply.....	7
	2.3.2 Connecting to a Computer or Computer Network.....	7
2.4	Switching on the Device.....	8
3	Control Panel.....	9
3.1	Structure of the Control Panel.....	9
3.2	Symbol Displays.....	10
3.3	Printer States.....	10
3.4	Key Functions.....	11
4	Loading Material.....	12
4.1	Loading Media from Roll.....	12
	4.1.1 Positioning the Media Roll on the Roll Retainer.....	12
	4.1.2 Printable media path.....	13
	4.1.3 Setting the Material Sensor.....	14
4.2	Loading Transfer Ribbon.....	14
4.3	Setting the Feed Path of the Transfer Ribbon.....	15
4.4	Setting the Head Locking Systems.....	16
5	Printing Operation.....	16
5.1	Printhead Protection.....	16
5.2	Directions for Double-Sided Printing.....	16
	5.2.1 Printing the same on both sides.....	17
	5.2.2 Printing variable text on both sides.....	18
	5.2.3 Backfeed.....	19
	5.2.4 Synchronisation in Cut Mode.....	19
6	Cleaning.....	19
6.1	Cleaning Information.....	19
6.2	Cleaning the Print Rollers.....	19
6.3	Cleaning the Printheads.....	20
7	Fault Correction.....	21
7.1	Types of Errors.....	21
7.2	Problem Solution.....	21
7.3	Error Messages and Fault Correction.....	22
8	Media.....	24
8.1	Media Dimensions.....	24
8.2	Cut-out Mark Dimensions.....	25
9	Licences.....	26
10	Index.....	27

1 Introduction

1.1 Instructions

Important information and instructions in this documentation are designated as follows:



Danger!

Draws your attention to an exceptionally grave, impending danger to your health or life.



Warning!

Indicates a hazardous situation that could lead to injuries or material damage.



Attention!

Draws attention to possible dangers, material damage or loss of quality.



Notice!

Gives you tips. They make a working sequence easier or draw attention to important working processes.



Environment!

Gives you tips on protecting the environment.



Handling instruction



Reference to section, position, illustration number or document.



Option (accessories, peripheral equipment, special fittings).

Zeit

Information in the display.

1.2 Intended Use

- The device is manufactured in accordance with the current technological status and the recognised safety rules. However, danger to the life and limb of the user or third parties and/or damage to the device and other tangible assets can arise during use.
- The device may only be used for its intended purpose and it must be used with regard to safety hazards as stated in the operating manual.
- The device printer is intended exclusively for printing suitable materials that have been approved by the manufacturer. Any other use or use going beyond this shall be regarded as improper use. The manufacturer/supplier shall not be liable for damage resulting from unauthorised use; the user shall bear the risk alone.
- Usage for the intended purpose also includes complying with the operating manual, including the manufacturer's maintenance recommendations and specifications.



Notice!

The complete documentation is included in the scope of delivery on CD ROM, and can also currently be found in the Internet.

1.3 Safety Instructions

- The device is configured for voltages of 100 to 240 V AC. It must be used with an earthed socket
- Only connect the device to other devices which have a protective low voltage.
- Switch off all devices (computer, printer, accessories) before connecting or disconnecting.
- The device may only be used in a dry environment, do not expose it to moisture (sprays of water, mists, etc.).
- Do not use the device in an explosive atmosphere.
- Do not use the device close to high-voltage power lines.
- If the device is operated with the cover open, ensure that people's clothing, hair, jewellery etc. do not come into contact with the exposed rotating parts.
- The device or parts of it, especially the printheads can become hot while printing. Do not touch during operation, and allow to cool down before changing material and before disassembly.
- Risk of crushing when closing the cover. Touch the cover at the outside only. Do not reach into the swivel range of the cover.
- Perform only those actions described in this operating manual.
Work going beyond this may only be performed by trained personnel or service technicians.
- Unauthorised interference with electronic modules or their software can cause malfunctions.
- Other unauthorised work on or modifications to the device can also endanger operational safety.
- Always have service work done in a qualified workshop, where the personnel have the technical knowledge and tools required to do the necessary work.
- There are various warning stickers on the device. They draw your attention to dangers.
Warning stickers must therefore not be removed, as then you and other people cannot be aware of dangers and may be injured.
- The maximum sound pressure level LpA is less than 70 dB(A).

**Danger!**

Danger to life and limb from power supply.

- ▶ **Do not open the device casing.**

1.4 Environment



Obsolete devices contain valuable recyclable materials that should be sent for recycling.

- ▶ Send to suitable collection points, separately from residual waste.

The modular construction of the printer enables it to be easily disassembled into its component parts.

- ▶ Send the parts for recycling.



The electronic circuit board of the device is equipped with a lithium battery.

- ▶ Take old batteries to collection boxes in shops or public waste disposal centres.

2 Installation

2.1 Device Overview

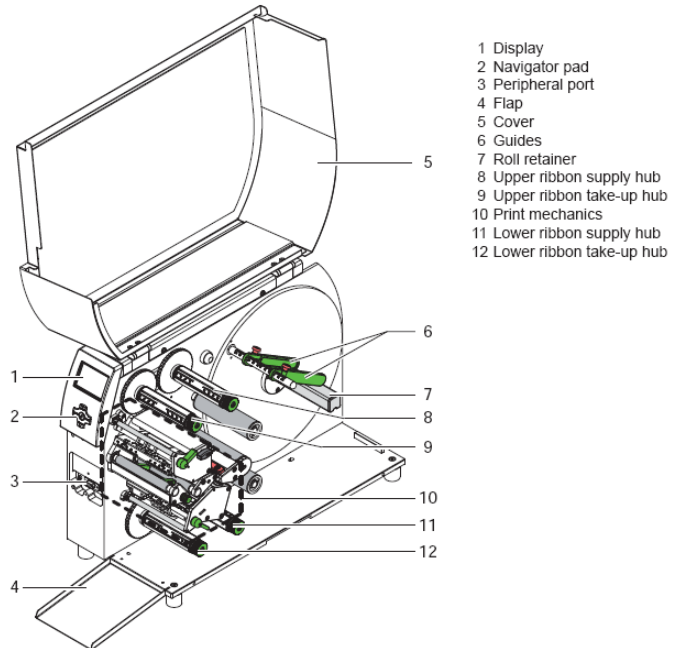

- 1 Display
- 2 Navigator pad
- 3 Peripheral port
- 4 Flap
- 5 Cover
- 6 Guides
- 7 Roll retainer
- 8 Upper ribbon supply hub
- 9 Upper ribbon take-up hub
- 10 Print mechanics
- 11 Lower ribbon supply hub
- 12 Lower ribbon take-up hub

Fig. 1 Overview

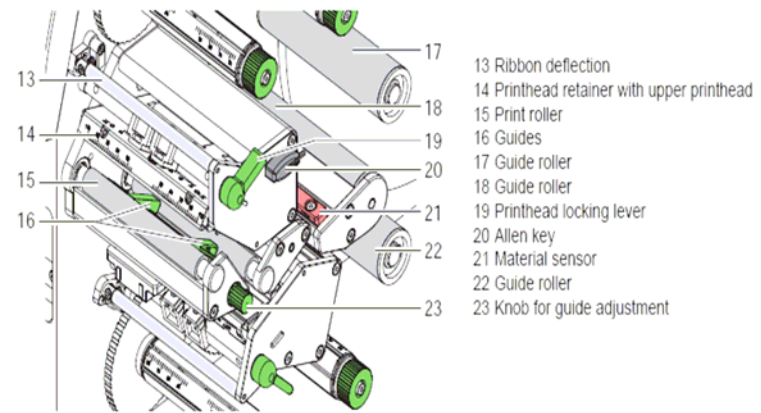

- 13 Ribbon deflection
- 14 Printhead retainer with upper printhead
- 15 Print roller
- 16 Guides
- 17 Guide roller
- 18 Guide roller
- 19 Printhead locking lever
- 20 Allen key
- 21 Material sensor
- 22 Guide roller
- 23 Knob for guide adjustment

Fig. 2 Print mechanics - upper print unit

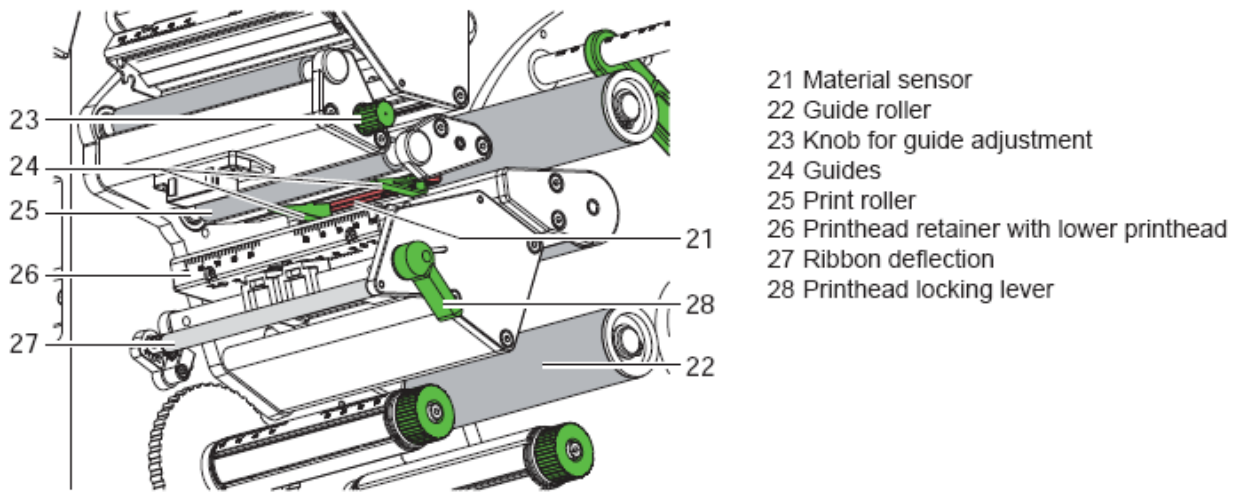

Fig. 3 Print mechanics - lower print unit

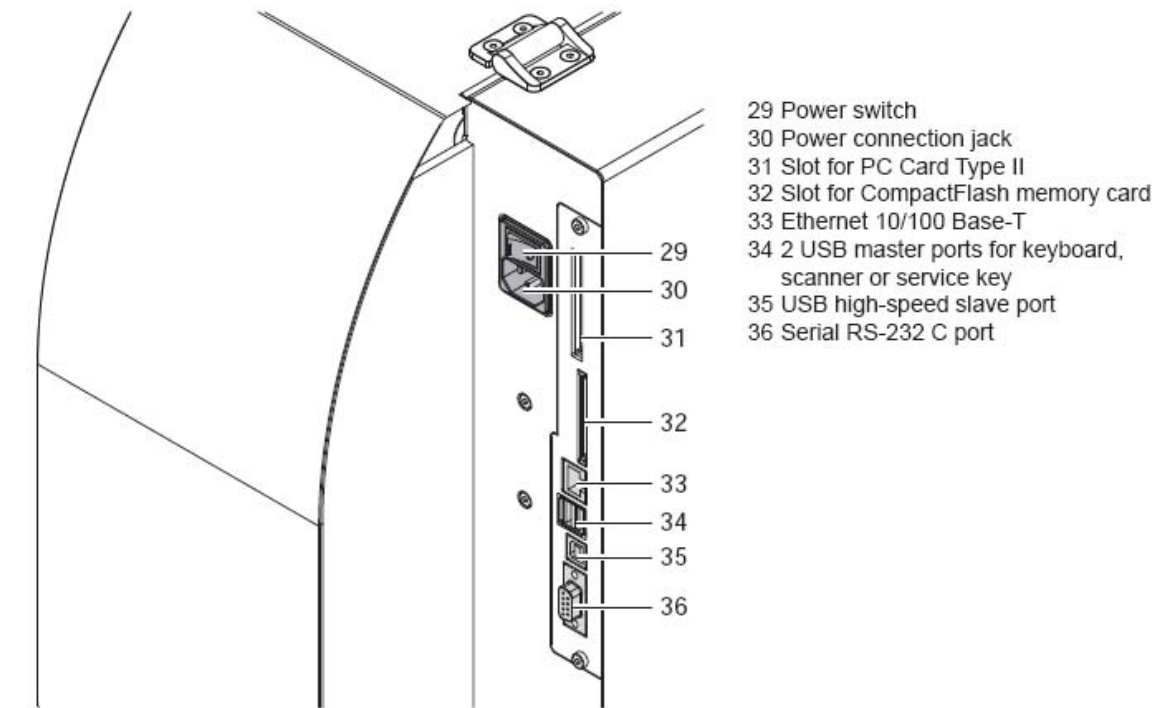

Fig. 4 Connections

2.2 Unpacking and Setting-up the Printer

- ▶ Lift the transfer printer out of the box via the straps.
- ▶ Check transfer printer for damage which may have occurred during transport.
- ▶ Set up printer on a level surface.
- ▶ Remove foam transportation safeguards near the printhead.
- ▶ Check delivery for completeness.

Contents of delivery:

- Transfer printer
- Power cable
- Documentation
- Documentation on CD-ROM



Notice!

Please keep the original packaging in case the printer must be returned.



Attention!

The device and printing materials will be damaged by moisture and wetness.

Set up transfer printers only in dry locations protected from splash water.

2.3 Connecting the Device

The standard available interfaces and connectors are shown in figure 4.

2.3.1 Connecting to the Power Supply

The printer is equipped with a wide area power unit. The device can be operated with a supply voltage of 230 V~/50 Hz or 115 V~/60 Hz without adjustment.

1. Check that the device is switched off.
2. Plug the power cable into the power connection socket (30).
3. Plug the power cable into a grounded socket.

2.3.2 Connecting to a Computer or Computer Network



Attention!

Inadequate or no grounding can cause malfunctions during operations.

Ensure that all computers and cables connected to the transfer printer are grounded.

- ▶ Connect the transfer printer to a computer or network by a suitable cable.

For details of the configuration of the individual interfaces ▷ Configuration Manual

2.4 Switching on the Device

When all connections have been made:

- ▶ Switch the printer on at the power switch (29).

The printer performs a system test, and then shows the system status `ready` in the display.

If an error occurs during the system test, the symbol  and type of error are displayed.

3 Control Panel

3.1 Structure of the Control Panel

The user can control the operation of the printer with the control panel, for example:

- Issuing, interrupting, continuing and cancelling print jobs,
- Setting printing parameters, e.g. heat level of the printhead, print speed, interface configuration, language and time of day (▷ Configuration Manual),
- Start the test functions (▷ Configuration Manual),
- Control stand-alone operation with a memory module (▷ Configuration Manual),
- Update the firmware (▷ Configuration Manual).

Many functions and settings can also be controlled by software applications or by direct programming with a computer using the printer's own commands. ▷ Configuration Manual for details.

Settings made on the control panel make the basic settings of the transfer printer.



Notice!

It is advantageous, whenever possible, to make adaptations to various print jobs in the TagPrint Pro software.

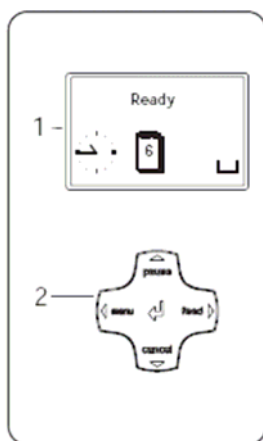

Fig. 4 Control Panel

The control panel consists of a graphic display (1) and the navigator pad (2) with five integrated keys.

The graphic display indicates the current status of the printer and the print job, indicates faults and shows the printer settings in the menu.

3.2 Symbol Displays

The symbols shown in the following table may appear in the status line of the display, depending on the printer configuration. They enable the current printer status to be seen quickly. For the configuration of the status line ▶ the Configuration Manual.

Table 1 Symbol displays

Symbol	Description	Symbol	Description	Symbol	Description
	Clock		Ethernet link status		User memory in the clock circuit
	Date sheet		Temperature of the printhead		Used memory
	Date/time digital		PPP funds		Input buffer
	Ribbon supply		Debug window for abc programs		Access to memory card
	Wi-Fi signal strength		Control of the lower display line is handed over to an abc program		Printer is receiving data

3.3 Printer States

Table 2 Printer states

State	Display	Description
Ready	Ready and configured symbol displays, such as time and date	The printer is in the ready state and can receive data.
Printing label	Printing label and the number of the printed label in the print job.	The printer is currently processing an active print job. Data can be transmitted for a new print job. The new print job will start when the previous one has finished.
Pause	Pause and the symbol	The printing process has been interrupted by the operator.
Correctable error	and the type of error and the number of labels still to be printed.	An error has occurred that can be rectified by the operator without interrupting the print job. The print job can be continued after the error has been rectified.
Irrecoverable error	and the type of error and the number of labels still to be printed.	An error has occurred that cannot be rectified without interrupting the print job.
Critical error	and the type of error	An error occurs during the system test. ▶ Switch the printer off and then on again at the power switch or ▶ Press cancel key. Call Service if the fault occurs persistently.
Power Save Mode	and the key lighting is switched off	If the printer is not used for a lengthy period, it automatically switches to power save mode. ▶ To exit power save mode: Press any key on the navigator pad.

3.4 Key Functions

The key functions depend on the current printer state:

- Active functions: Labels and symbols on the navigator pad keys light up.
- Active functions light up white in print mode (e. g. **menu** or **feed**).
- Active functions light up orange in the offline menu (arrows, key ↵).

Table 3 Key functions in the print mode

Key	Display	State	Function	
menu	lights	Ready	Ready	To the offline menu
feed	lights	Ready	Ready	Feeds a blank label
pause	lights	Ready	Ready	After the end of a print job, reprint the last label
		Printing label	Printing label	Interrupt print job, printer goes into "Pause" state
		Pause	Pause	Continue the print job, printer goes into "Printing label" state
	flashes		Correctable error	Continue the print job after rectifying the error, printer goes into "Printing label" state
cancel	lights	Ready	Ready	Delete internal memory, the last label can no longer be reprinted.
		Printing label	Printing label	Short press → cancels the current print job Longer press → cancels the current print job and deletes all print jobs
		Pause	Pause	
	flashes		Correctable error	
			Irrecoverable error	
↵	lights		Error	Call Help - Concise information for rectifying the fault will be displayed

Table 4 Key functions in the offline menu

Key	Menu	Parameter setting	
		Parameter choice	Numeric value
↑	Return from a submenu	-	Increase of the number at the cursor position
↓	Jump into a submenu	-	Decrease of the number at the cursor position
←	Menu option to the left	Sheets to the left	Cursor shift to the left
→	Menu option to the right	Sheets to the right	Cursor shift to the right
↵	Start of a selected menu option	Confirmation of the selected value	
	Pressing 2 s: Leaving the offline menu	Pressing 2 s: Abort without changing the value	

4 Loading Material



Notice!

For adjustments and simple installation work, use the accompanying Allen key located in the upper section of the print unit. No other tools are required for the work described here.

4.1 Loading Printable Media from Roll

4.1.1 Positioning the Media Roll on the Roll Retainer

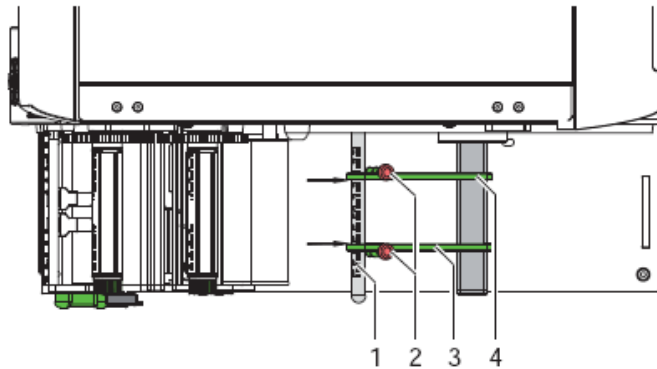

Fig. 6 Adjusting the guide at the roll retainer

1. Measure the width of the media roll.
2. Open cover.
3. Loosen knurled screws (2).
4. Adjust the marked faces of the guides (3, 4) at the scale of the guide axle (1) to the width of the media roll. Figure 6 shows the setting for a roll width of 54 mm.
5. Tighten knurled screws (2).
6. Swivel the outer guide (3) upwards.
7. Load label roll (5) on the roll retainer (6) in such a way that the media can be inserted into the print mechanics coming from above.
8. Supplying a longer label strip of approx. 50 cm.
9. Push the roll until it makes contact with the inner guide (4).
10. Swivel the outer guide (3) downwards. The roll must be braked slightly by the guides when supplying media. If necessary re-adjust symmetrically the guides.

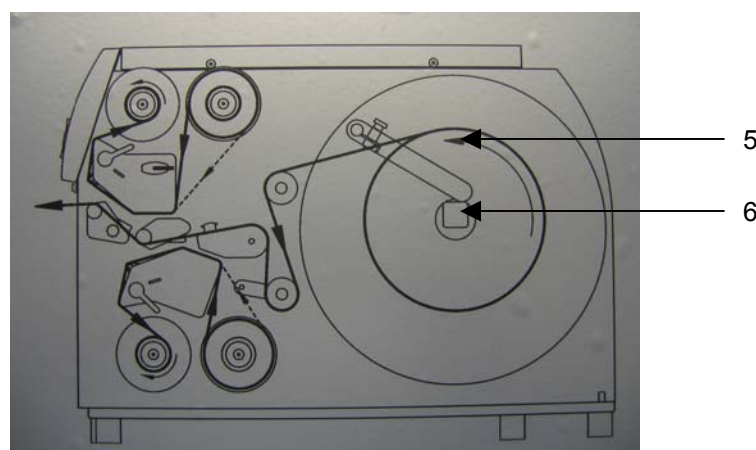

Fig. 7 Loading media from roll

4.1.2 Printable Media path

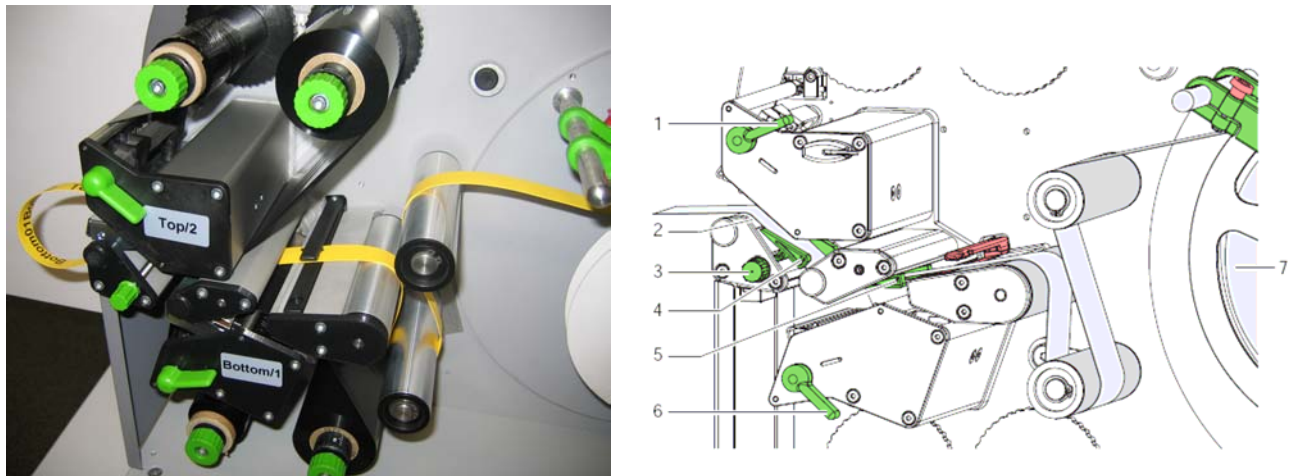
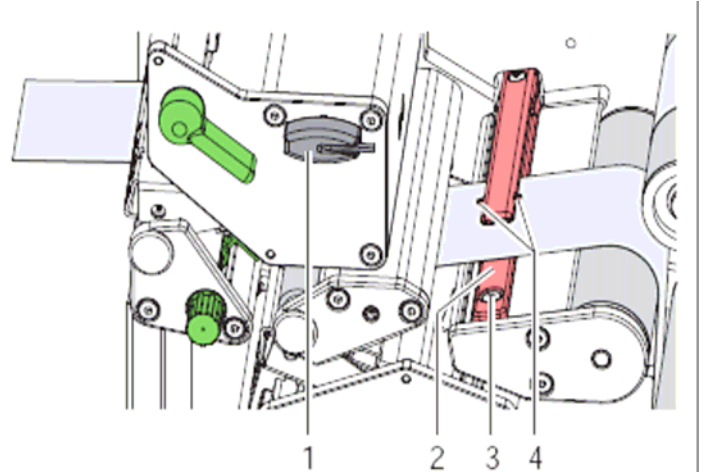
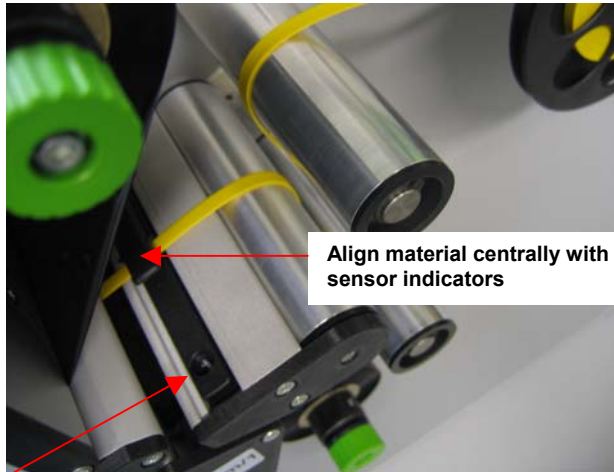

Fig. 8 Printable Media path

1. Turn lever (1) counterclockwise and lever (6) clockwise to lift both printheads.
2. Move guides (4, 5) apart with the knob (3) until the media can pass between them.
3. Guide media strip through the print mechanics as shown in figure 8 to the upper print roller (2) and place the strip between the guides (4, 5).
4. Move guides against the edges of the material by turning the knob (3).
5. Fix the media by closing the upper printhead.
6. Turn the media roll (7) clockwise to tighten the media.
7. Close the lower printhead

4.1.3 Setting the Material Sensor



Screw to lock sensor position

9a

9b

Figs. 9 a & b Setting the material sensor

The material sensor (2) can be shifted perpendicular to the direction of media flow for adaptation to the media. The sensor unit is marked with indicators (4) on the label sensor retainer.

- ▶ Slightly loosen the screw (3) with Allen key (1).
- ▶ Position sensor by moving it in such a way that the sensor can detect a gap or material
- ▶ Tighten the screw (3).

4.2 Loading Transfer Ribbon



Notice!

With direct thermal printing, do not load a transfer ribbon; if one has already been loaded, remove it.

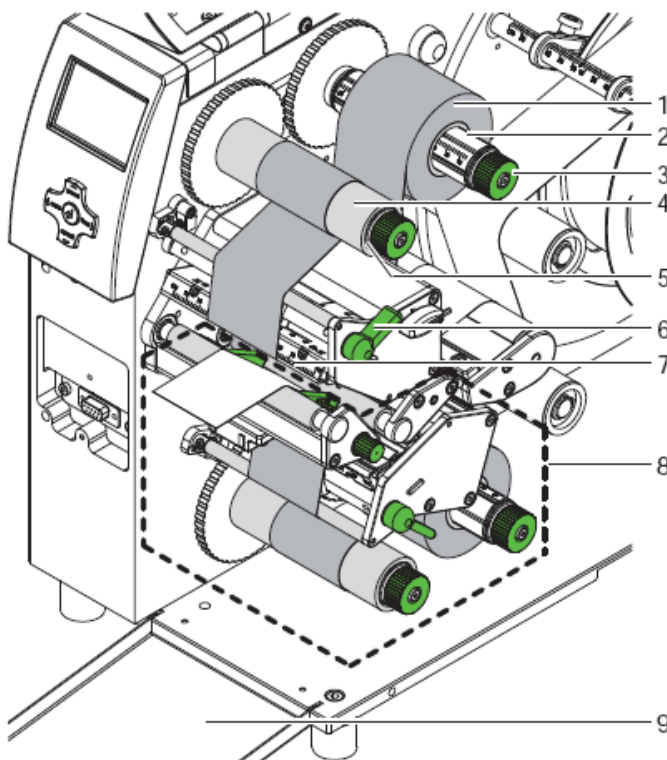

Fig. 10 Load transfer ribbon

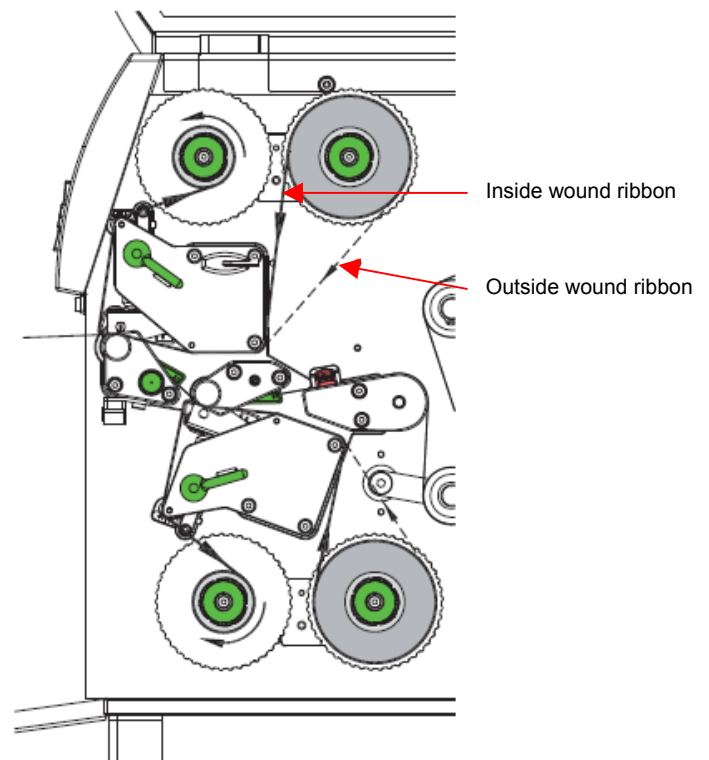

Fig. 11 Transfer ribbon feed path

1. Clean printheads before loading the transfer ribbon (▷ 6.3 on page ???)
2. Turn lever (6) anti-clockwise to lift the upper printhead.
3. Slide transfer ribbon roll (1) onto the ribbon supply hub (3) so that ink coating of the ribbon faces outward when being unwound.
4. Position the ribbon roll (1) in such a way that both ends of the roll show identical scale values.
5. Hold transfer ribbon roll (1) firmly and turn knob (3) on ribbon supply hub anti-clockwise until the transfer ribbon roll is secured.



Notice!

To rewind the transfer ribbon, use a core with a width between the width of the supply roll and 115 mm

6. Slide suitable transfer ribbon core (4) onto the transfer ribbon take-up hub (5). Position and secure it in the same way like the supply roll.
7. Guide transfer ribbon through the print unit as shown in Fig. 11.
8. Secure starting end of transfer ribbon to middle of the transfer ribbon core (4) with adhesive tape. When using cores which are wider than the transfer ribbon use the scale (7) at the printhead retainer to adjust the path of the ribbon. Ensure anti-clockwise rotation direction of the transfer ribbon take-up hub.
9. Turn transfer ribbon take-up hub (5) anticlockwise to smooth out the feed path of the transfer ribbon.
10. Turn lever (6) clockwise to lock the printhead.
11. Open the flap (9) and load transfer ribbon to the lower print unit (8) and repeat the instructions as above

4.3 Setting the Feed Path of the Transfer Ribbon

Transfer ribbon wrinkling can lead to print image errors. Transfer ribbon deflection can be adjusted so as to prevent wrinkles.



Notice!

The adjustment is best carried out during printing.

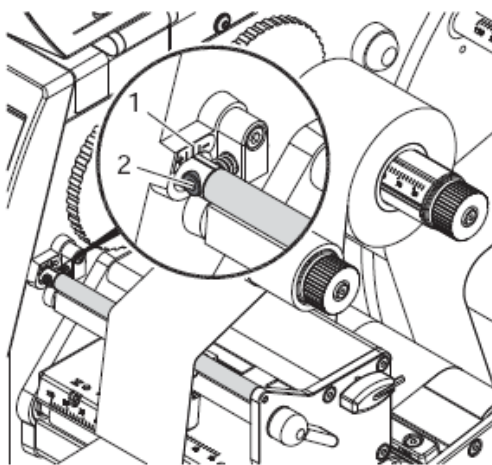

Fig. 12 Setting the upper ribbon feed path

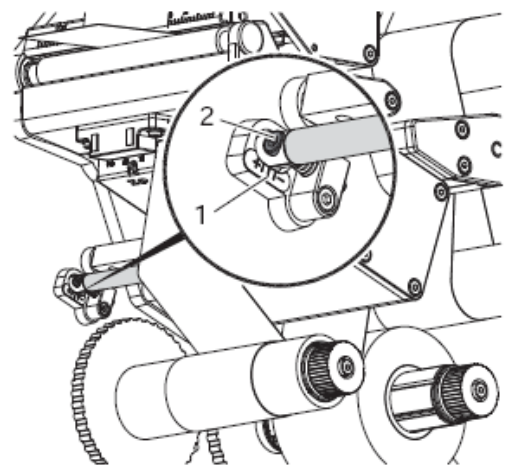

Fig. 13 Setting the lower ribbon feed path

1. Read current setting on the scale (1) and record if necessary.
2. Turn screw (2) with Allen key and observe the behaviour of the ribbon.
In the + direction, the inner edge of the ribbon is tightened, and the outer edge is tightened in the - direction.

4.4 Setting the Head Locking Systems

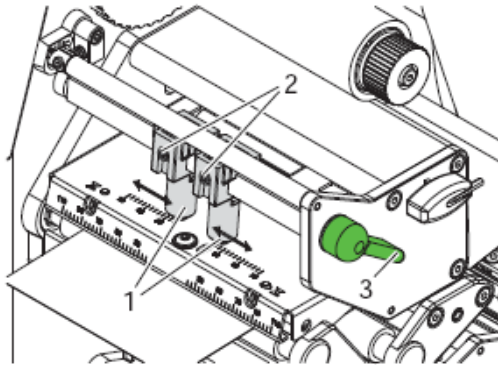

Fig. 14 Setting the upper head locking system

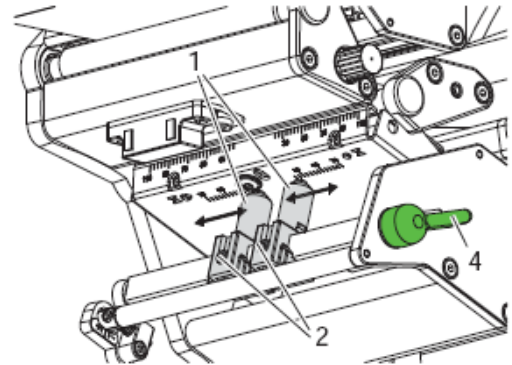

Fig. 15 Setting the lower head locking system

The adjustable printhead pressure is via the two pillars (1). In the standard mode the pillars are set in the middle of the printhead retainer. This setting can be used for the most applications.

If the print density decreases in the outer areas when using very large media, the pillars can be displaced.

1. Ribbon should be removed to access the printhead pressure pillars.:
2. Turn lever (3) clockwise and the lever (4) counterclockwise to lock the printheads.
3. Loosen threaded pins (2) at the pillars (1) with Allen key.
4. Displace pillars symmetrically as necessary maximal to the scale value 70.
5. Tighten the threaded pins (2).

5 Printing Operation

5.1 Printhead Protection



Attention!

Printhead damage caused by improper handling!

- ▶ Do not touch the heating elements of the printheads with the fingers or sharp objects.
- ▶ Ensure material is clean.
- ▶ Ensure that the material surfaces are smooth. Rough surfaces will reduce the service life of the printhead.
- ▶ Print with the lowest possible printhead temperature.

5.2 Directions for Double-Sided Printing

The printer is ready for operation when all connections have been made and labels and, if applicable, the transfer ribbon have been loaded.

5.2.1 Printing the same on both sides

Use TagPrint Pro to open a template design and follow the example below

Eg TLFx64x50

Label guide size and shape
 Set width to 50 = length of sleeve
 Set height to 12= approx 2 x diameter tubing

Select sheet size as user defined and landscape format
 Set width to 105.6 = printhead width
 Set length to 50

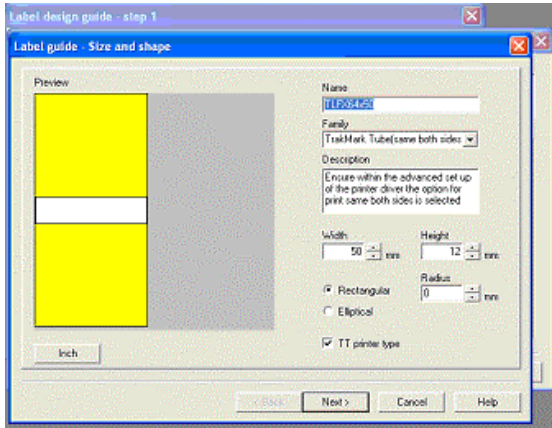

Media setting continuous

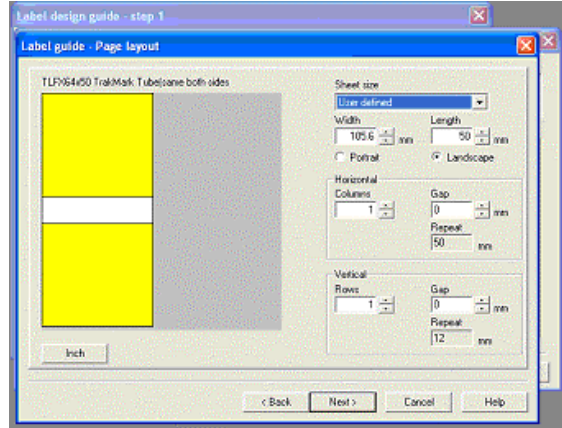

Set Top margin to be equal to bottom

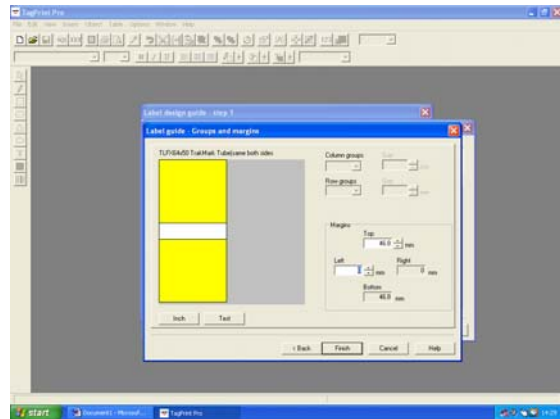
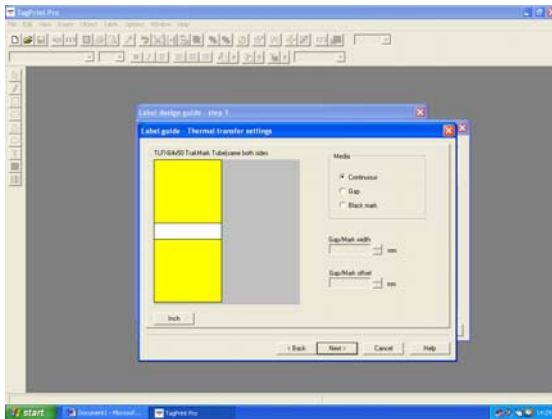

Open template and select text

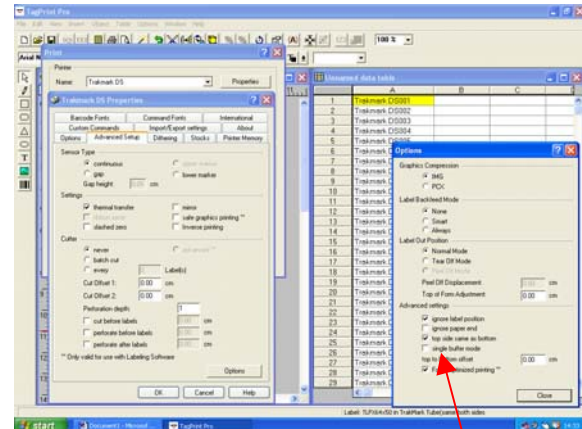
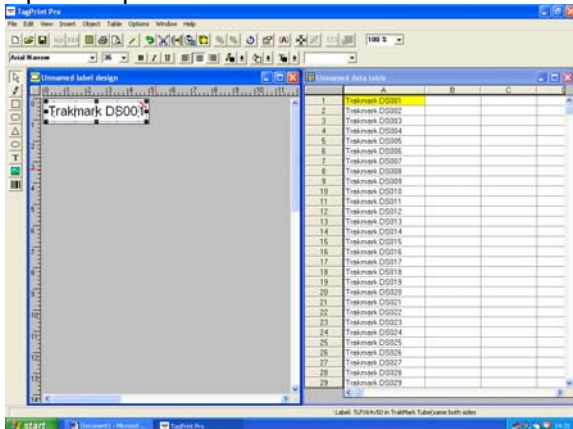

Ensure within the advanced set up of the printer driver the option for print same both sides is selected

5.2.2 Printing variable text on both sides

Use TagPrint Pro to open a template design and follow the example below
Eg TLFX32X50

Label guide size and shape
Set width to 211.2 = 2x width of printhead
Set height to 50= length of sleeve

Select sheet size as user defined and landscape format
Set width to 211.2 = 2 x printhead width
Set length to 50 = length of sleeve

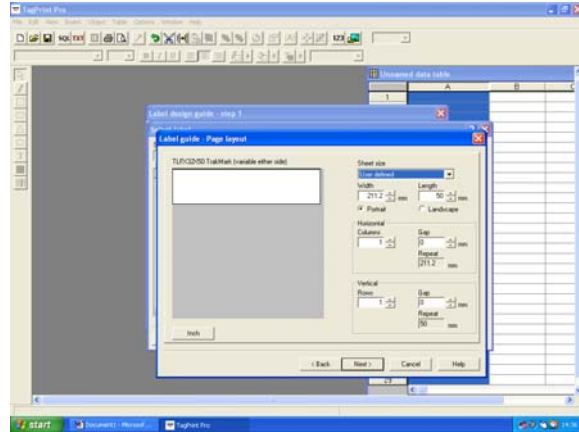
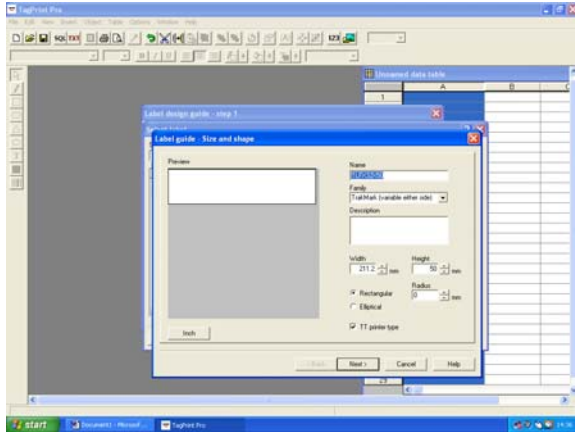

Media setting continuous

Set Top and Left margin to zero

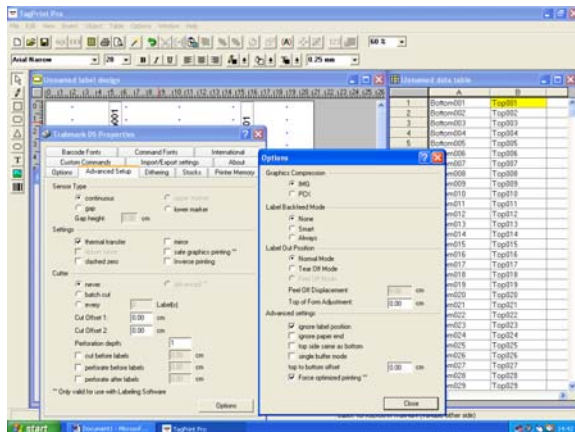
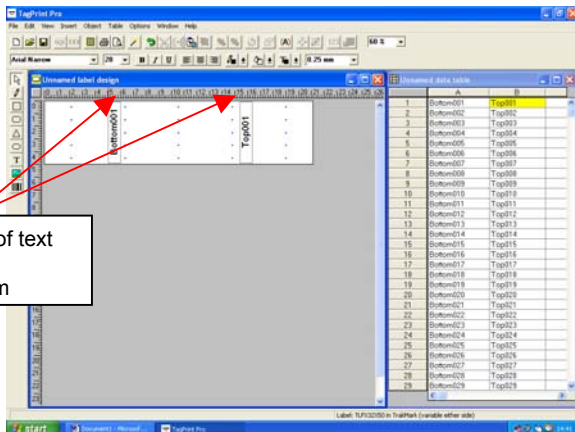
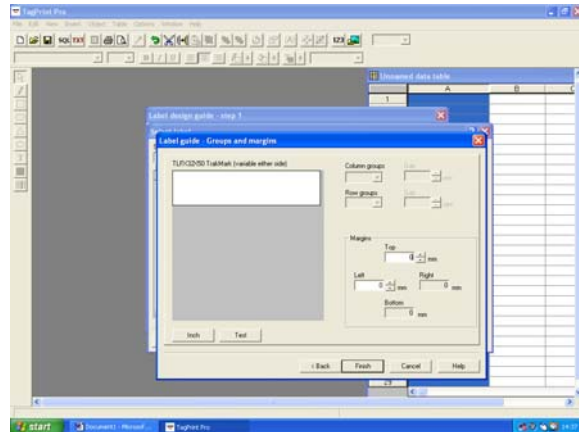
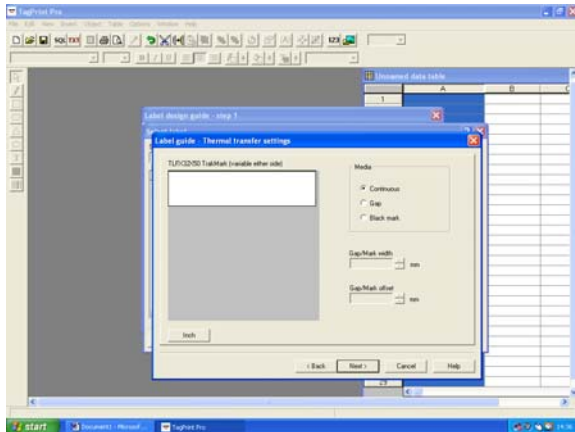

Text area must be rotated 90°

Selection for Advanced set up in printer driver

5.2.3 Backfeed

**Notice!**

Feeding back the material to the lower printhead in the cut mode or between print jobs is not advised.

To avoid the backfeed:

- ▶ Activate the option "ignore label position" in the printer driver.

5.2.4 Synchronisation in Cut Mode

- ▶ To guarantee the correct length of the first label a cut prior print job is required:
- ▶ Activate the option "cut before labels" in the printer driver.

Cleaning

6.1 Cleaning Information

**Danger!**

Risk of death via electric shock!

- ▶ Disconnect the printer from the power supply before performing any maintenance work.

The TrakMark DS printer requires very little maintenance.

It is important to clean the thermal printheads regularly. This ensures a consistently good printed image and reduces premature wear of the printhead.

Otherwise, the maintenance is limited to monthly cleaning of the device.

**Attention!**

The printer can be damaged by aggressive cleansers.

Do not use abrasive cleaners or solvents for cleaning the external surfaces or modules.

- ▶ Remove dust and paper fluff from the print area with a soft brush or vacuum cleaner.
- ▶ The cover of the printer can be cleaned with a standard cleanser.

6.2 Cleaning the Print Rollers

Accumulations of dirt on the print rollers may impair the media transport and the print quality.

- ▶ Lift the printheads.
- ▶ Remove media and transfer ribbon from the printer.
- ▶ Remove deposits with roller cleaner and a soft cloth.
- ▶ If the roller appears damaged, replace it ▶ Service Manual.

6.3 Cleaning the Printheads

Cleaning intervals: direct thermal printing - every media roll change
 thermal transfer printing - every ribbon roll change

Substances may accumulate on the printheads during printing and adversely affect printing, e.g. differences in contrast or vertical stripes.

**Attention!**

Printheads can be damaged!

Do not use sharp or hard objects to clean the printheads.

Do not touch protective glass layer of the printheads.

**Attention!**

Risk of injury from the hot printhead lines.



Ensure that the printheads have cooled down before starting cleaning.

- ▶ Lift the printheads.
- ▶ Remove media and transfer ribbon from the printer.
- ▶ Clean printhead with cotton swab or soft tissue dipped in pure alcohol.
- ▶ Allow printheads to dry for 2–3 minutes before commissioning the printer.

7 Fault Correction

7.1 Types of Errors

The diagnostic system indicates on the screen if an error has occurred. The printer is set into one of the three possible error states according to the type of error.

State	Display	Key	Remark
Correctable error		pause flashes cancel lights	▷ 3.4 on page 11
Irrecoverable error		cancel flashes	
Critical fault		-	

7.2 Problem Solution

Table 6 Problem solution

Problem	Cause	Remedy
Transfer ribbon creases	Transfer ribbon deflection not adjusted	Adjust the transfer ribbon ▶ deflection 4.3 page 16
	Transfer ribbon too wide	Use a transfer ribbon slightly wider than width of reel
Print image has smears or voids	Printhead is dirty	Clean printhead ▶ 6.3 page 20
	Temperature too high	Decrease temperature via the print driver
	Unsuitable combination of media and transfer ribbon	Select correct ribbon
Printer does not stop after transfer ribbon runs out	Direct thermal printing is chosen in the printer driver	Change to thermal transfer printing
Printer prints a sequence of characters instead of the label format	Printer is in ASCII dump mode	Cancel ASCII dump mode
Printer moves media but ribbon remains static	Transfer ribbon incorrectly loaded	Check and if necessary, correct the transfer ribbon web and the orientation of the media
	Unsuitable combination of media to ribbon	Select correct ribbon
Vertical white lines in the print image	Printhead is dirty	Clean printhead ▶ 6.3 on page 20
	Printhead is defective (failure of heat elements)	Change printhead ▶ Service Manual
Print image is irregular, one side is lighter	Printhead is dirty	Clean printhead ▶ 6.3 on page 20
	Printhead pressure pillars unevenly spaced	Set pressure evenly across printhead

7.3 Error Messages and Fault Correction

Table 7 Error Messages and Fault Correction

Error message	Cause	Remedy
ADC malfunction	Hardware error	Switch the printer off and then on. If error recurs call service.
Barcode error	Invalid barcode content, e.g. alphanumeric characters in a numerical barcode	Correct the barcode content.
Barcode too big	The barcode is too big for the allocated area of the label	Reduce the size of the barcode or move it.
Battery low	Battery of the PC card is flat	Replace battery in the PC card.
Buffer overflow	The input buffer memory is full and the computer is still transmitting data.	Use data transmission via protocol (preferably RTS/CTS).
Card full	No more data can be stored on the memory card	Replace card.
Cutter blocked	Cutter cannot return into its home position and stays in an undefined position	Switch off the printer. Remove material. Switch on the printer. Restart print job. Change material
	No cutter function	Switch the printer off and then on. If error recurs call service.
Cutter jammed	The cutter is unable to cut the labels but is able to return into its home position	Press the cancel key. Change material.
Device not conn.	Programming addresses a non-existent device	Either connect this device or correct the programming.
File not found	Requested file is not on the card	Check the contents of the card.
Font not found	Error with the selected download font	Cancel current print job, change font.
FPGA malfunction	Hardware error	Switch the printer off and then on. If error recurs call service.
Head error	Hardware error	Switch the printer off and then on. If error recurs replace printhead.
Head open	Printhead not locked	Lock printhead.
Head too hot	Printhead is overheated	After pausing the print job will be continued automatically. If the fault recurs repeatedly, reduce the heat level or the print speed via software.
Invalid setup	Error in the configuration memory	Re-configure printer. If error recurs call service.
Memory overflow	Current print job contains too much information, e.g. selected font, large graphics	Cancel current print job. Reduce amount of data to be printed.
Name exists	Duplicate usage of field name in the direct programming	Correct programming
No DHCP server	The printer is configured for DHCP, but there is no DHCP server, or the DHCP server is not currently available.	Switch off DHCP in the configuration, and assign a fixed IP address. Please contact your network administrator.
No label found	The label format as set in the software does not correspond with the real label format	Cancel current print job. Change the label format set in the software. Restart print job.
	Printer is loaded with continuous paper, but the software is set on labels	Cancel current print job. Change the label format set in the software. Restart the print job.
No label size	The format size is not defined in the programming.	Check programming.
No Link	No network link	Check network cable and connector. Please contact your network administrator.
No record found	Refers to the optional memory card; database access error	Check programming and card contents.

Error message	Cause	Remedy
No SMTP server	The printer is configured for SMTP, but there is no SMTP server, or the SMTP server is not currently available.	Switch off SMTP in the configuration. Caution! Then a warning cannot be sent by e-mail (EAlert). Please contact your network administrator.
No Timeserver	Timeserver is selected in the configuration, but there is no Timeserver, or the Timeserver is not currently available.	Switch off Timeserver in the configuration. Please contact your network administrator.
Out of paper	Out of label roll	Load labels.
	Error in the paper feed	Check media feed.
Out of ribbon	Out of transfer ribbon	Insert new transfer ribbon.
	Transfer ribbon melted during printing	Cancel current print job. Change the heat level via software. Clean the printhead ▷ 6.3 on page 20 Load transfer ribbon Restart print job.
	The printer is loaded with thermal labels, but the software is set to transfer printing	Cancel current print job. Set software to direct thermal printing. Restart print job
Protocol error	Printer has received an unknown or invalid command from the computer.	Press the pause key to skip the command or press the cancel key to cancel the print job.
Read error	Read error when reading from the memory card	Check data of the card. Backup data, reformat card.
Remove ribbon	Transfer ribbon is loaded although the printer is set to direct thermal printing	for direct thermal printing remove ribbon for thermal transfer printing set the printer in the configuration or in the software to transfer printing
Structural err.	Error in the file list of the memory card, data access is uncertain.	Format memory card.
Unknown card	Card not formatted, Type of card not supported	Format card, use different type of card.
USB error Device stalled	A USB device has been detected, but it is not working.	Do not use the USB device.
USB error Too much current	The USB device consumes too much current.	Do not use the USB device.
USB error Unknown device	Failure to detect USB device	Do not use the USB device.
Voltage error	Hardware error	Switch the printer off and then on. If error recurs call service. It is shown which voltage has failed. Please note.
Write error	Hardware error	Repeat the write process, reformat card.
Write protected	PC card write protection is activated.	Deactivate the write protection.
Wrong revision	Error when updating the firmware. Firmware not compatible with the hardware version	Load the compatible firmware.

8 Media

8.1 Media Dimensions

Table 8 Media dimensions

Designation	Dim. in mm
Media width	10-110
Continuous heatshrink tubing (flattened)	3-85
Ladderstyle heatshrink tubing (flattened)	50-110
Media thickness	0,055-1.2
Height of material passage	4,5
Print zone height	5-1000
Feed length	>5
Cut length	>5
with cutter	>12
with perforator	>12
Perforation length	>5
* Note . Flexibility of media to allow the product to follow the radius of the print roller	

8.2 Cut-out Mark Dimensions

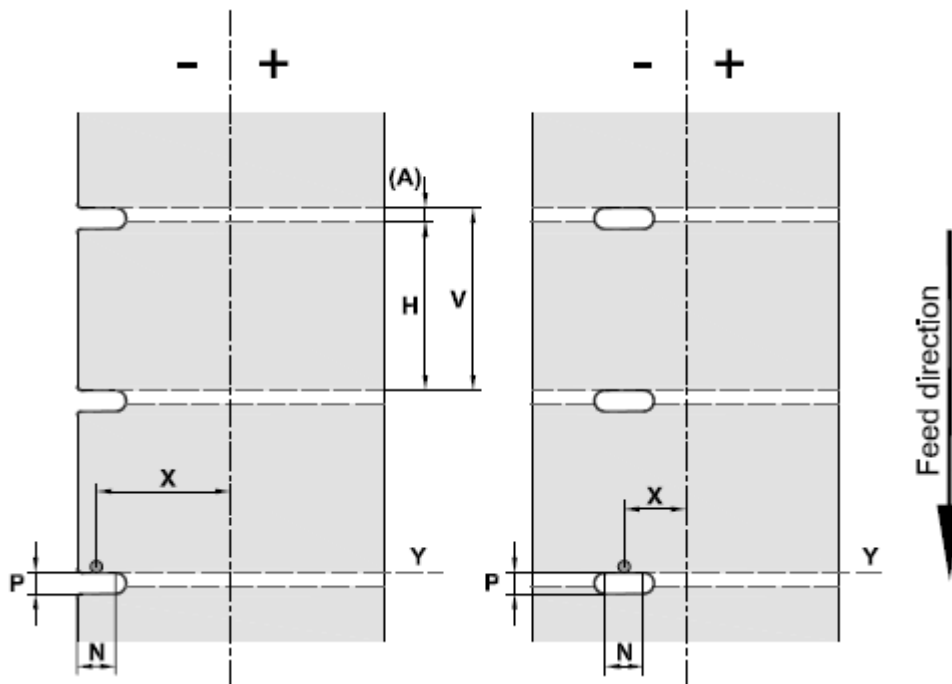

Fig. 19 Cut-out mark dimensions

Table 11 Cut-out mark dimensions

Dim.	Designation	Dim. in mm
H	Print zone height	5 - 1000
A	Print zone distance	> 2
V	Feed length	> 7
N	Width of cut-out	> 5
P	Height of cut-out	2 - 10
X	Distance cut-out - middle of media track = Distance gap/reflective sensor - middle of media track	-53 - ±0
Y	Sensor recognized virtual print zone front edge with gap sensor recognition	Rear edge cut-out

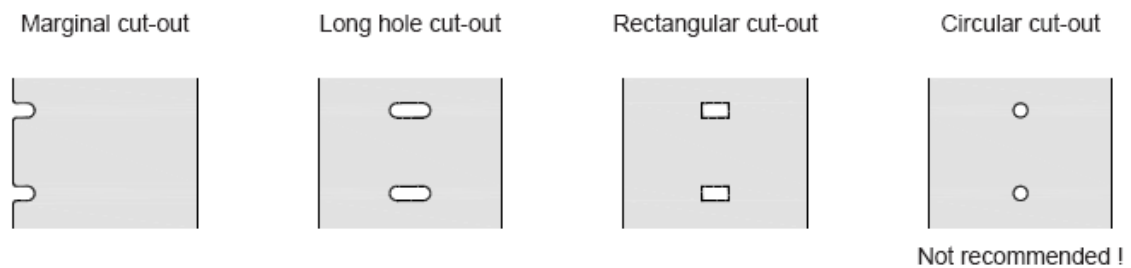

Fig. 20 Samples for cut-out marks

9 Licences

EU Declaration of Conformity

We declare herewith that as a result of the manner in which the machine designated below was designed, the type of construction and the machines which, as a result have been brought on to the general market comply with the relevant fundamental regulations of the EU Rules for Safety and Health. In the event of any alteration which has not been approved by us being made to any machine as designated below, this statement shall thereby be made invalid.

Device:

Transfer Printer / Thermal-direct Printer

Type:

TrakMark DS

Applied EU Regulations and Norms:

- | | |
|--|--|
| <ul style="list-style-type: none"> ● EC Machinery Regulations ● Safety of Machinery | 98/37/EU
EN ISO 12100-1:2003
EN ISO 12100-2:2003 |
| <ul style="list-style-type: none"> ● EC Voltage Regulations ● Data and Office Machine Safety | 2006/95/EU
EN 60950-1:2001 + A11:2004 |
| <ul style="list-style-type: none"> ● EC Electromagnetic Compatibility Regulations ● Threshold values for the interference of Data Machines ● Immunity characteristics
Limits and methods of measurement ● Limits for harmonic current emission ● Limits of voltage fluctuation and flicker | 2004/108/EU
EN 55022:1998 + A1:2000 + A2:2003 - Class A
EN 55024:1998 + A1:2001 + A2:2003
EN 61000-3-2:2000 + A2:2005
EN 61000-3-3:1995 + A1:2001 + A2:2003 |

10 Index

A		L	
Adapting the roll retainer.....	12	Lithium battery.....	4
B		Loading media.....	12
Backfeed.....	19	Loading printable media from roll.....	12
C		Loading transfer ribbon.....	14
Cleaning		M	
printhead.....	20	Material sensor setting.....	14
print roller.....	19	N	
Cleaning information.....	19	Navigator pad.....	9
Connecting.....	7	O	
Contents of delivery.....	7	Offline menu.....	11
Control panel.....	9	P	
Correctable error.....	10	Pause.....	10
Critical error.....	10	Power save mode.....	10
Cut-out marks.....	25	Power supply.....	4
		Print same both sides.....	17
		Print variable both sides.....	18
Cut mode.....	19	Printer states.....	10
D		Printhead	
Designing the print image.....	17	cleaning.....	20
Device overview.....	5,6	damage.....	20
Driver settings	17	Printing label.....	10
E		Print roller, cleaning.....	19
Environment.....	4	Problem solution.....	21
Errors		R	
correction.....	21	Ready.....	10
display.....	21	Ribbon deflection, setting.....	15
messages.....	22	S	
states.....	21	Safety instructions.....	4
types.....	21	Service work.....	5
EU Conformity Declaration.....	26	Supply voltage.....	8
G		Switching on.....	8
Graphic display.....	9	Symbol displays.....	9
H		T	
Head locking system, setting.....	16	TagPrint Pro Software	17
Help calling.....	11	U	
I		Unpacking.....	7
Important information.....	3	V	
Intended use.....	3	Voltage.....	4
Irrecoverable error.....	10	W	
K		Warning stickers.....	3
Key			
cancel.....	11		
enter.....	11		
feed.....	11		
menu.....	11		
pause.....	11		
Key functions.....	11		
offline menu.....	11		
print mode.....	11		